

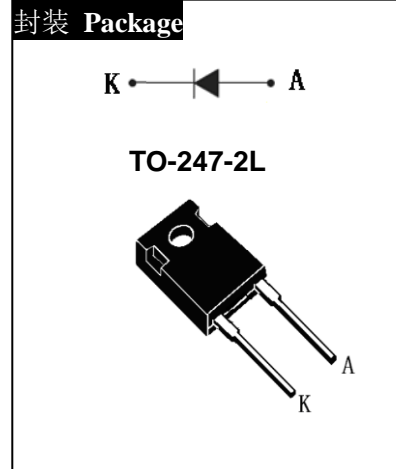

DP75C200A

主要参数 MAIN CHARACTERISTICS

IF(AV)	75A
VRRM	2000V
Tj(max)	150°C
VF (typ) (25°C)	1.2V



用途

- 输入整流
- 半导体开关和输出整流

APPLICATIONS

- Input rectification
- Semiconductors switches and output rectifiers

产品特性

- 低功耗，高效率
- 高可靠性
- 环保（RoHS）产品

FEATURES

- Low power loss, high efficiency
- High reliability
- RoHS product

订货信息 ORDER MESSAGE

订货型号 Order codes				印 记 Marking	封 装 Package
有卤-条管 Halogen-Tube	无卤-条管 Halogen Free-Tube	有卤-袋装 Halogen-Bag	无卤-袋装 Halogen Free-Bag		
DP75C200A-GL-B	DP75C200A-GL-BR	N/A	N/A	DP75C200A	TO-247-2L

**绝对最大额定值 ABSOLUTE RATINGS ($T_c=25^\circ\text{C}$)**

项 目 Parameter	符 号 Symbol	数 值 Value	单 位 Unit
最大反向重复峰值电压 Repetitive peak reverse voltage	V_{RRM}	2000	V
正向平均整流电流 Average forward current	$I_{F(AV)}$	75	A
峰值单脉冲浪涌电流 Peak one Cycle Surge Forward Current(Non-Repetitive) $t=8.3\text{ms}$	I_{FSM}	1000	A
结温 Junction Temperature	T_j	-50~+150	$^\circ\text{C}$
储存温度 Storage temperature range	T_{STG}	-50~+150	$^\circ\text{C}$

电特性 ELECTRICAL CHARACTERISTICS ($T_c=25^\circ\text{C}$ unless otherwise specified)

项 目 Parameter	测试条件 Tests conditions	最小值 Value(min)	典型值 Value(typ)	最大值 Value(max)	单 位 Unit
V_{RRM}	$I_R=100\mu\text{A}$	2000			V
I_R	$T_j=25^\circ\text{C}$			30	μA
	$T_j=150^\circ\text{C}$			500	μA
V_F	$T_j=25^\circ\text{C}$		1.2	1.3	V
	$T_j=150^\circ\text{C}$		1.18	1.25	V

热特性 THERMAL CHARACTERISTICS

项 目 Parameter	符 号 Symbol	最小值 Value(min)	最大值 Value(max)	单 位 Unit
结到管壳的热阻 Thermal resistance from junction to case	$R_{th(j-c)}$		0.30	$^\circ\text{C}/\text{W}$



特征曲线 ELECTRICAL CHARACTERISTICS (curves)

Fig.1 TYPICAL FORWARD CHARACTERISTICS

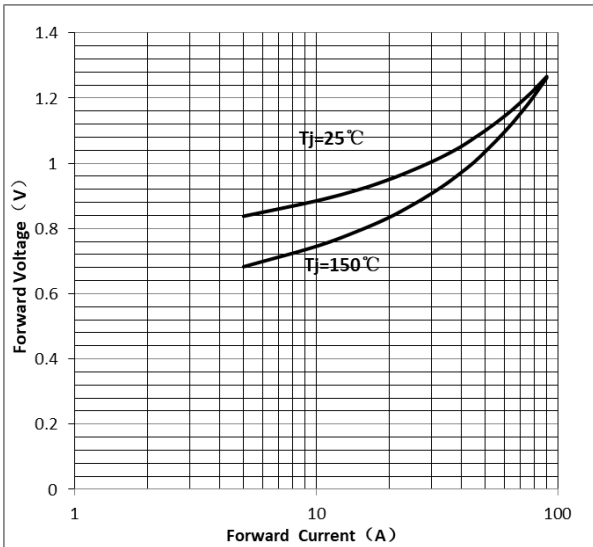
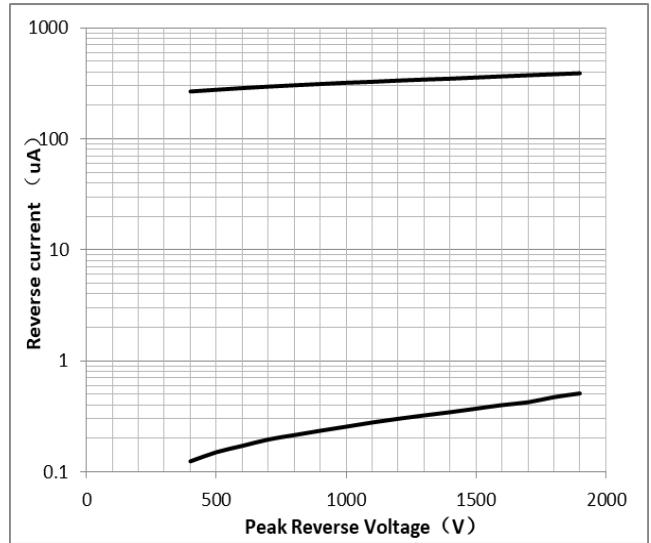
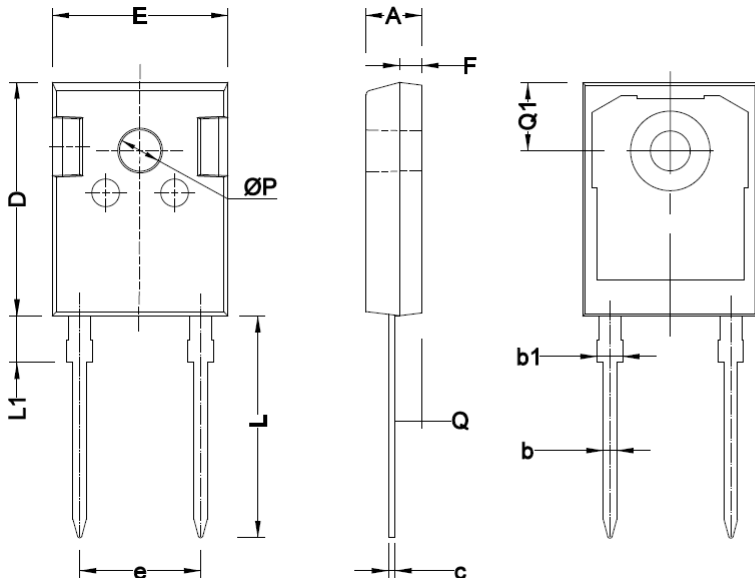

Fig.2 TYPICAL REVERSE CHARACTERISTICS



TO-247-2L

单位 Unit : mm



SYMBOL	MM	
	MIN	MAX
A	4.80	5.20
b	1.10	1.30
b1	1.95	2.25
c	0.50	0.70
D	20.80	21.20
E	15.60	16.00
F	1.85	2.15
e	10.73	11.03
L	19.62	20.22
L1	3.93	4.33
ØP	3.40	3.80
Q	2.26	2.56
Q1	6.00	6.40



注意事项

1. 吉林华微电子股份有限公司的产品销售分为直销和销售代理，无论哪种方式，订货时请与公司核实。
2. 购买时请认清公司商标，如有疑问请与公司本部联系。
3. 在电路设计时请不要超过器件的绝对最大额定值，否则会影响整机的可靠性。
4. 本说明书如有版本变更不另外告知。

NOTE

1. Jilin Sino-microelectronics co., Ltd sales its product either through direct sales or sales agent , thus, for customers, when ordering , please check with our company.
2. We strongly recommend customers check carefully on the trademark when buying our product, if there is any question, please don't be hesitate to contact us.
3. Please do not exceed the absolute maximum ratings of the device when circuit designing.
4. Jilin Sino-microelectronics co., Ltd reserves the right to make changes in this. specification sheet and is subject to change without prior notice.

联系方式

吉林华微电子股份有限公司

公司地址：吉林省吉林市深圳街 99 号

邮编：132013

总机：86-432-64678411

传真：86-432-64665812

网址：www.hwdz.com.cn

CONTACT

JILIN SINO-MICROELECTRONICS CO., LTD.

ADD: No.99 Shenzhen Street, Jilin City, Jilin Province, China.

Post Code: 132013

Tel: 86-432-64678411

Fax: 86-432-64665812

Web Site: www.hwdz.com.cn

